

AMERICAN RANGE

Quality Commercial Cooking Equipment

ARMG

ARMG HEAVY DUTY MANUAL CONTROL GRIDDLE

American Range ARMG series manual* griddles are design engineered to provide the ultimate in performance and durability. As with all of our heavy duty countertop equipment, they are built to the highest commercial standards to ensure years of trouble free service, featuring superior frame construction and stainless steel exterior for easy maintenance. Combine all of this and our affordable prices and you have the best value for your budget.



*see our ARTG-series for thermostatically controlled models.



ARMG

STANDARD FEATURES

- Stainless steel front and sides.
- Heavy gauge chassis.
- Compact design for counter top use.
- Heavy, highly polished steel griddle plate.
- Available in 3/4" (standard) or 1" (optional) thickness.
- 30,000 BTU/hr steel "U" burners.
- S/S non clog pilots for instant ignition for each burner.
- Durable die cast, chrome plated control knobs.
- Optional 4" legs or equipment stands available.
- AGA and CGA design certified, NSF listed.
- One year limited warranty, parts and labor.



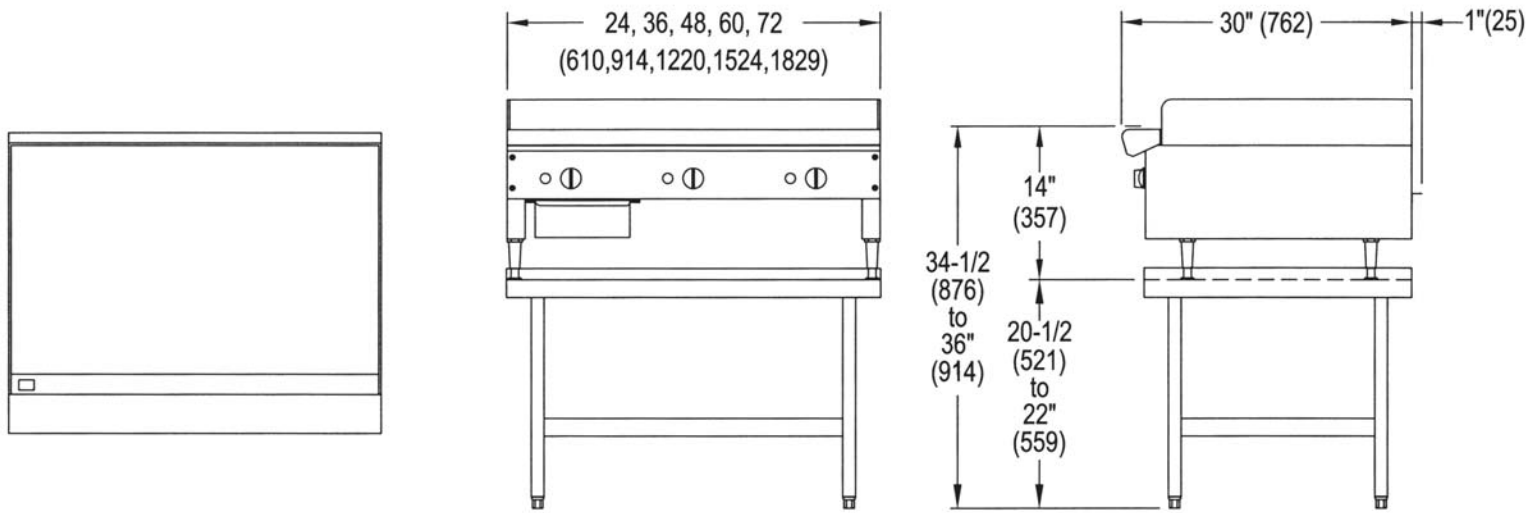

HEAVY DUTY MANUAL GRIDDLES: Highly polished 3/4" thick plates

MODEL	WIDTH	DEPTH	HEIGHT	BURNERS	TOTAL BTU	KW	SHIP. WT. Lbs.	Kg.
ARMG-24	24"	30"	10"	2	60,000	17.58	203	92
ARMG-36	36"	30"	10"	3	90,000	26.37	310	140
ARMG-48	48"	30"	10"	4	120,000	35.16	365	165
ARMG-60	60"	30"	10"	5	150,000	43.96	421	191
ARMG-72	72"	30"	10"	6	180,000	52.75	498	225

HEAVY DUTY MANUAL GRIDDLES: Highly polished 1" thick plates

MODEL	WIDTH	DEPTH	HEIGHT	BURNERS	TOTAL BTU	KW	SHIP. WT. Lbs.	Kg.
ARMG-124	24"	30"	10"	2	60,000	17.58	325	147
ARMG-136	36"	30"	10"	3	90,000	26.37	435	197
ARMG-148	48"	30"	10"	4	120,000	35.16	635	288
ARMG-160	60"	30"	10"	5	150,000	43.96	755	342
ARMG-172	72"	30"	10"	6	180,000	52.75	895	406

STANDARD FEATURES

- Highly polished steel griddle plate, 3/4" (19) thick. (Optional 1" (25.4) thick plate available).
- "U" shape burners, 30,000 BTU/hr. for every 12" (305) of griddle surface.
- Manual control for each burner.
- Available with open burners: Easy cleaning, removable cast iron two piece burner heads, allow high gas output of 32,000 BTU, highest in the industry.
- AGA and CGA design certified. NSF listed
- One year limited warranty, parts and labor.

OPTIONS

- 4" (102) legs adjustable
- Equipment stand
- Partial grooving
- Open burner combinations
- Saute and wok burner heads (open burner).
- S/S wok ring (open burner).
- Easy cleaning, removable cast iron two piece burner heads, allow high gas output of 32,000 BTU, highest in the industry.

Gas: 5.0"W.C.Natural, 10.0"W.C.Propane. Specify type of gas and altitude if over 2000 feet. 3/4" NPT Gas inlet.

Clearances: From non-combustible walls, 0". When unit is placed next to combustible walls, clearances must exceed 12" (305) on sides, and 7" (179) from rear.

American Range Corporation is a quality manufacturer of commercial cooking equipment. Because of continuing product improvements these specifications are subject to change without prior notice.

